

# Rotary Measuring Technology

## Absolute encoders, Singleturn, hollow shaft version



### Stainless steel (Niro) Type 5876



#### Your benefit

- Integrative Technology®  
Patented new type of construction integrates all components; use of an opto-asic and 6-layer multilayer technology now on just a single PCB
- resolution up to 14 bits.
- Improved EMC-characteristics and highest shock resistance on the market (>2500 m/s<sup>2</sup>, 6 ms acc. to DIN IEC 68-2-27).
- SSI or parallel interface

- Various options (e.g. LATCH, SET...)
- Temperature and ageing compensation
- Short-circuit proof outputs

#### Product features

- resolution up to 14 bits, singleturn
- ø 58 mm
- Housing ø 12 mm
- IP 66
- Gray, Binary or BCD code

#### Mechanical characteristics:

Speed with seal <sup>1)</sup> :	max. 6000 min <sup>-1</sup>
Rotor moment of inertia:	approx. 6 x 10 <sup>-6</sup> kgm <sup>2</sup>
Starting torque:	< 0.05 Nm
Weight:	approx. 0.6 kg
Protection acc. to EN 60 529 with sea:	IP 67
EX approval for hazardous areas:	optional zone 2 and 22
Working temperature with seal:	-20° C ... +80 °C <sup>2)3)</sup>
Shaft/body:	stainless steel H7
Shock resistance acc. to DIN-IEC 68-2-27:	2500 m/s <sup>2</sup> , 6 ms
Vibration resistance acc. to DIN-IEC 68-2-6:	100 m/s <sup>2</sup> , 10...2000 Hz

<sup>1)</sup> For continuous operation max. 1500 min<sup>-1</sup>

<sup>2)</sup> Non-condensing

<sup>3)</sup> 70 °C with cable

#### Electrical characteristics:

Interface type:	Synchronous Serial (SSI)	Synchronous Serial (SSI)	Parallel	Parallel
Supply voltage (U <sub>B</sub> ):	5 V DC (± 5 %)	10 ... 30 V DC	5 V DC (± 5 %)	10 ... 30 V DC
Output driver:	RS 485	RS 485	Push-pull	Push-pull
Current consumption typ.:	89 mA	89 mA	109 mA	109 mA
(no load) max.:	138 mA	138 mA	169 mA	169 mA
Permissible load/channel:	max. +/- 20 mA	max. +/- 20 mA	max. +/- 10 mA	max. +/- 10 mA
Word change frequency:	max. 15.000/s	max. 15.000/s	40.000/s	40.000/s
SSI pulse rate min./max.:	100 kHz/500 kHz	100 kHz/500 kHz	-	-
Signal level high:	typ. 3.8 V	typ. 3.8 V	min. 3.4 V	min. U <sub>B</sub> – 2.8 V
Signal level low (I <sub>Load</sub> = 20 mA):	typ. 1.3 V	typ. 1.3 V	-	-
(I <sub>Load</sub> = 10 mA):	-	-	max. 1.5 V	max. 1.8 V
(I <sub>Load</sub> = 1 mA):	-	-	max. 0.3 V	-
Rise time t <sub>r</sub> (without cable):	max. 100 ns	max. 100 ns	max. 0.2 µs	max. 1 µs
Fall time t <sub>f</sub> (without cable):	max. 100 ns	max. 100 ns	max. 0.2 µs	max. 1 µs
Short circuit proof outputs <sup>1)</sup> :	yes	yes <sup>2)</sup>	yes	yes
Reverse connection protection at U <sub>B</sub> :	no	yes	no	yes
UL certified	File 224618			
Conform to CE requirements acc. to EN 61000-6-2, EN 61000-6-4 and EN 61000-6-3				
RoHS compliant acc. to EU guideline 2002/95/EG				

<sup>1)</sup> If supply voltage correctly applied

<sup>2)</sup> Only one channel allowed to be shorted-out:

(If U<sub>B</sub>=5 V, short-circuit to channel, 0 V, or +U<sub>B</sub> is permitted)

(If U<sub>B</sub>=5-30 V, short-circuit to channel or 0 V is permitted)

# Rotary Measuring Technology

## Absolute encoders, Singleturn, hollow shaft version



### Stainless steel (Niro) Type 5876

#### Control Inputs:

##### Up/down input to switch the counting direction

By default, if glancing at the shaft side, absolute encoders deliver increasing code values when shaft rotates clockwise (cw). If the shaft rotates counter-clockwise (ccw), the output delivers accordingly decreasing code values.

As long as the Up/down input receives the corresponding signal (high), this feature is reversed. Clockwise rotation delivers decreasing code values while counter-clockwise rotation delivers increasing code values.

The response time is:

for 5 V DC supply voltage, 0.4 ms  
for 10 ... 30 V DC supply voltage, 2 ms.

##### SET input

This input is used to reset (to zero) the encoder. A control pulse (high) sent to this input allows storing the current position value as new zero position in the encoder.

#### Switching level of the control inputs

Supply voltage:	5 V DC	10 ... 30 V DC
low	≤ 1.7 V	≤ 4.5 V
high	≥ 3.4 V	≥ 8.7 V

##### Note :

Before activating the SET input after supplying the encoder with the supply voltage, a counting direction (cw or ccw) must be defined univocally on the Up/down input!

The response time is : for 5 V DC supply voltage, 0.4 ms  
for 10 ... 30 V DC supply voltage, 2 ms.

##### LATCH input

This input is used to „freeze“ the current position value. The position value will be statically available on the parallel output as long as this input will remain active (high).

The response time is : for 5 V DC supply voltage, 140 µs,  
for 10 ... 30 V DC supply voltage, 200 µs.

#### Terminal assignment (SSI interface with 8 pin plug):

Sig.:	0 V	+U <sub>B</sub>	+T	-T	+D	-D	SET	V/R	
Pin:	1	2	3	4	5	6	7	8	
Col.:	WH	BN	GN	YE	GY	PK	BU	RD	

T: Clock signal

D: Data signal

ST: SET input. The current position value is stored as new zero position.

VR: Up/down input. As long as this input is active, decreasing code values are transmitted when shaft turning clockwise.

Isolate unused outputs before initial start-up

#### Top view of mating side, male contact base:

8-pin plug

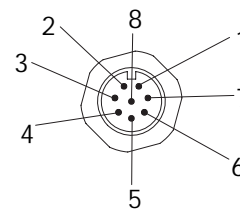

#### Terminal assignment (Parallel interface, 14 bits and max. 2 options, cable version):

Sig.:	0V	+U <sub>B</sub>	1	2	3	4	5	6	7	8	9	10	11	12	13	SET V/R	V/R Latch	14	⊥	
Col.:	WH	BN	GN	YE	GY	PK	BU	RD	BK	VT	GY PK	RD BU	WH GN	BN GN	WH YE	YE BN	WH GY	GY BN		

# Rotary Measuring Technology

## Absolute encoders, Singleturn, hollow shaft version

### Stainless steel (Niro) Type 5876

Dimensions:

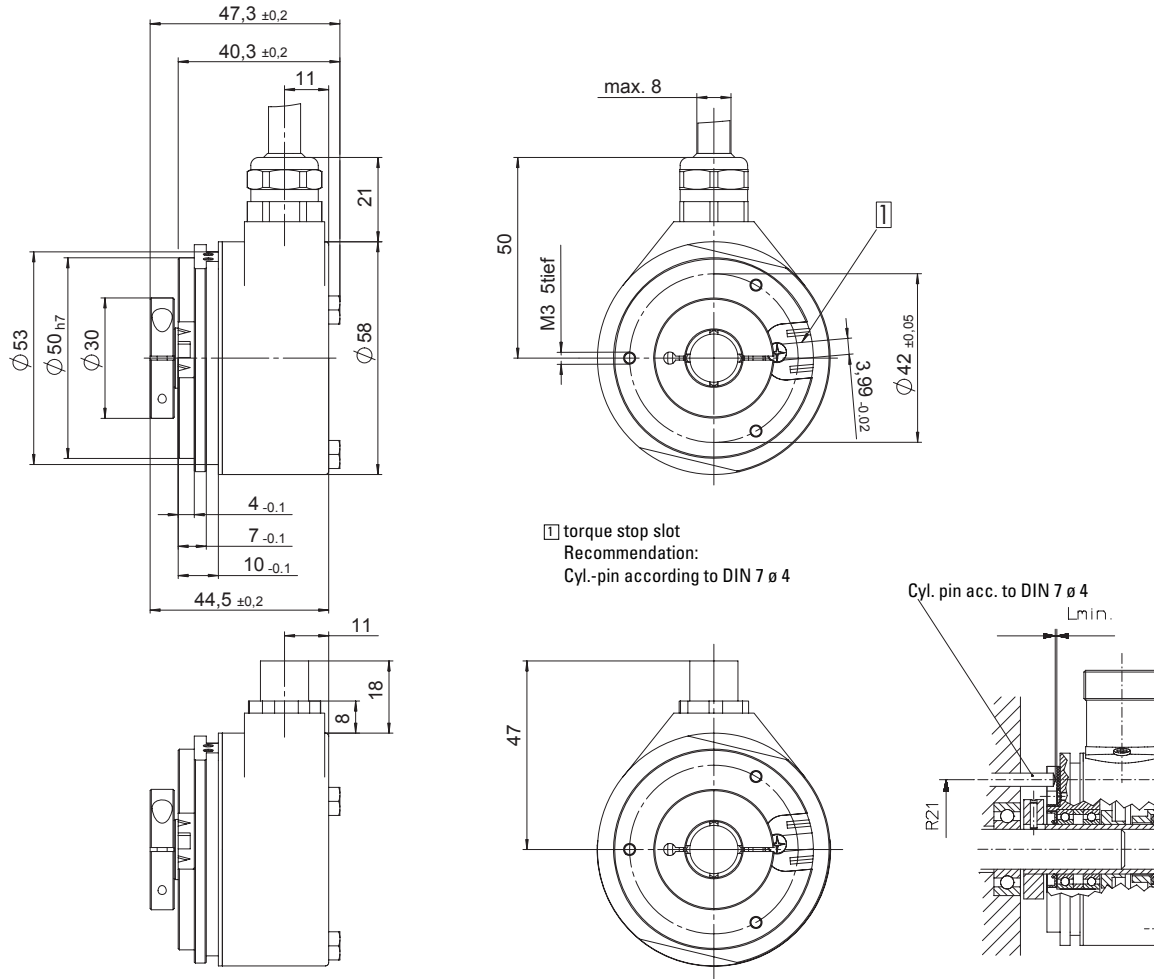

#### Mounting advice:

- 1) When mounting a hollow shaft encoder, we recommend using the torque stop slot or the stator coupling.
- 2) When mounting the encoder, ensure that the dimension  $L_{min}$  is larger than the maximum axial play of the drive. Otherwise there is a danger that the device could mechanically seize up.

# Rotary Measuring Technology

## Absolute encoders, Singleturn, hollow shaft version



### Stainless steel (Niro) Type 5876

Order code:

**8.5876.XXXX.XXXX**

**Type**

**Flange**

1 = **Flange with through shaft**

2 = Flange with blind hollow shaft

**Hollow shaft**

6 = ø 10 mm

**8 = ø 12 mm**

**Interface and supply voltage**

1 = SSI with 5 V supply voltage

**2 = SSI with 10 ... 30 V supply voltage**

3 = Parallel with 5 V supply voltage

4 = Parallel with 10 ... 30 V supply voltage

**Options**

**2 = SET<sup>1)</sup> and V/R**

3<sup>2)</sup> = SET and Latch<sup>1)</sup>

4<sup>2)</sup> = V/R <sup>1)</sup> and Latch

Alarm output on request

<sup>1)</sup> With 14 Bit parallel output and 17 pin plug

<sup>2)</sup> Not with SSI interface

**Code type and division**

Gray/Binary

250, 360<sup>1)</sup>, 500, 720<sup>1)</sup>, 900, 1000<sup>1)</sup>, 1024 (10 Bit)<sup>1)</sup>, 1250, 1440, 1800, 2000, 2500, 2880, 3600<sup>1)</sup>, 4000, 4096 (12 Bit)<sup>1)</sup>, 5000, 7200, 8192 (13 Bit)<sup>1)</sup>, 16384 (14 Bit)<sup>1)</sup>

BCD

250, 360<sup>1)</sup>, 500, 720<sup>1)</sup>, 900, 1000<sup>1)</sup>, 1024 (10 Bit)<sup>1)</sup>, 1250, 1440, 1800, 2000

Other on request<sup>1)</sup>

<sup>1)</sup> Preferred divisions use corresponding table

**Type of connection**

1<sup>a)</sup> = radial cable 1 m PVC-cable)

**2<sup>b)</sup> = radial plug without mating connector**

*Preferred types are indicated in bold*

**Accessories:**

Corresponding mating connector to connection type 2 - at SSI interface

8 pin plug 05.CMB8181-0

**Mounting set:**

Ord.-No. 8.0010.4600.0000 coupling two wings for high dynamic application

Order-No.: 8.0010.4D00.0000

Tether arm short

Order-No.: 8.0010.4R00.0000

<sup>a)</sup>In connection with parallel- or SSI- output

<sup>b)</sup>In connection with SSI-output

#### Code type and division with parallel output

Interface and supply voltage, version 3 or 4 (Parallel):

Division	Order code Gray/Gray-Excess	Order code Binary	Order code BCD
250	E02	B02	D02
<b>360<sup>1)</sup></b>	<b>E03</b>	B03	D03
500	E05	B05	D05
<b>720<sup>1)</sup></b>	<b>E07</b>	B07	D07
900	E09	B09	D09
<b>1000<sup>1)</sup></b>	<b>E01</b>	B01	D01
<b>1024 (10 Bit)</b>	<b>G10</b>	<b>B10</b>	D10
1250	E12	BA2	DA2
1440	E14	BA1	DA1
1800	E18	B18	D18
2000	E20	B20	D20
2500	E25	B25	
2880	E28	B28	
3600 <sup>1)</sup>	E36	B36	
4000	E40	B40	
<b>4096 (12 Bit)</b>	<b>G12</b>	<b>B12</b>	
5000	E50	B50	
7200	E72	B72	
<b>8192 (13 Bit)</b>	<b>G13</b>	<b>B13</b>	
<b>16384 (14 Bit)</b>	<b>G14</b>	<b>B14</b>	

Preferred divisions are indicated in bold

#### Code type and division for encoder with SSI-Output

Interface and supply voltage, version 1 or 2 (SSI):

Division	Order code Gray	Order code Binary
1024 (10 Bit)	G10	B10
4096 (12 Bit)	G12	B12
8192 (13 Bit)	G13	B13
16384 (14 Bit)	G14	B14